

# SPLICE/VALVE VAULT FC4848R

Roadway Application **R**

Load: See table below

## Applications:

Roadway areas for telephony, power, CATV, DOT and other applications.

## Features & Benefits:

- ◆ Cast iron ring and cover for maximum load.
- ◆ Round lid can't fall through opening, prevents damage to cable and equipment.
- ◆ Break-away internal brackets reduce damage caused by back-hoe excavation mishaps (pull-ups & yank-outs).
- ◆ Lightweight and high-strength FRP provides long life and quick and easy installation.
- ◆ Sunlight resistant for long life over a wide range of temperature extremes.
- ◆ Larger "clear" opening maximizes work area, perfect for large valve applications.
- ◆ Interlock for concrete sidewalk retention and/or lift handle prevents tilting or frost heaving.

## Options:

- ◆ EMS marker for quick and easy identification.
- ◆ OEM labeling (cast-in identification).
- ◆ Cable racks, strut inserts, and terminators.
- ◆ Customizing services - knockouts, bolt and conduit holes.

## Ordering Information:

Specify part numbers listed in the table below. Special configurations available. Consult factory for more information.

**Pallet Quantity:** 1

Stainless steel hex head bolts are standard on bolt down covers. Boltless covers are also available. Consult factory.

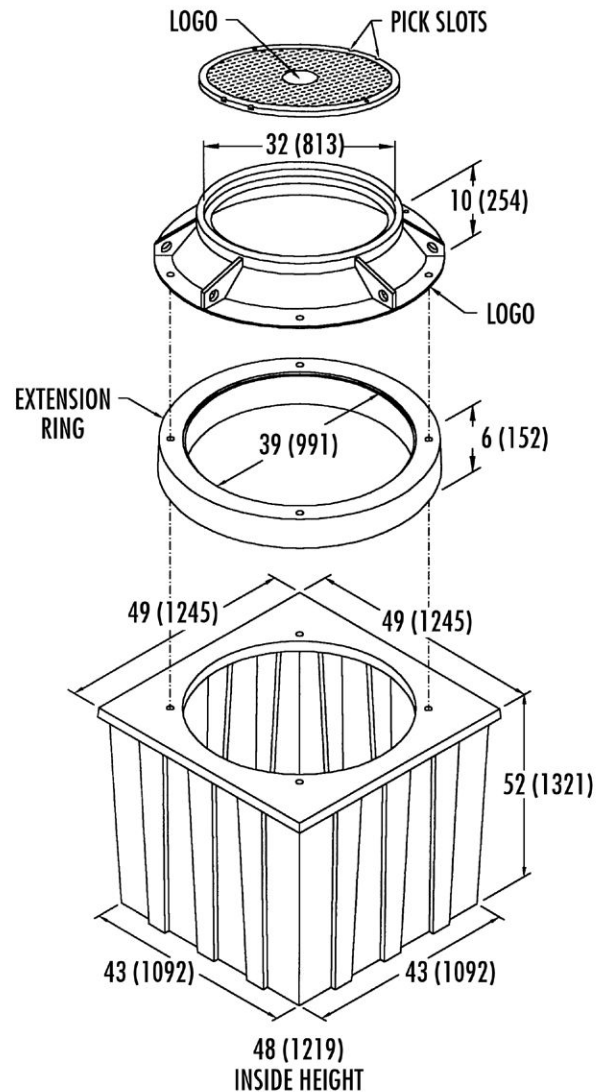

Dimensions: Inches (mm)  
Weight: lbs (kg)

Part No.	Description	Material	Weight
FCB484824F17	Box, 24", Straight, 45K	FRP body/PC ring	305 (139)
FCB484836F17	Box, 36", Straight, 45K	FRP body/PC ring	417 (190)
FCB484848F17	Box, 48", Straight, 45K	FRP body/PC ring	463 (210)
CCC540000E17	Cover & Ring - H20/44	Cast Iron	300 (136)
PCR48000607	Grade ring for slab roof 48" dia.	6" thick concrete	170 ( 77)
PCR48001207	Grade ring for slab roof 48" dia.	12" thick concrete	330 (150)