

SPLICE/VALVE BOX PC1212DP

Applications:

Sidewalk, driveway and parking lot areas for telephony, power, CATV, DOT, water utility and other applications. Turf and irrigation for residential, commercial, golf courses and parks and recreation.

Features & Benefits:

- ◆ Heavy-duty construction increases product life cycle.
- ◆ Replaces concrete - high strength for durability and lightweight for quick and easy installation.
- ◆ Unique stackable wall design allows for grade adjustment after installation.
- ◆ Non-metallic, non-conductive materials eliminate grounding requirements.
- ◆ Excellent resistance from sunlight, fertilizers and other chemicals.
- ◆ Larger "clear" opening maximizes work area, perfect for large valve applications.

Options:

- ◆ EMS marker for quick and easy identification.
- ◆ OEM labeling (cast-in identification).
- ◆ Gaskets, cable racks, strut inserts, and terminators.
- ◆ Customizing services - knockouts, bolt and conduit holes.

Ordering Information:

Specify part numbers listed in the table below. Special colors available. Consult factory for more information.

Pallet Quantity: 12", 27 per pallet
24", 18 per pallet

Sidewalk Application **SW**

Driveway/Parking Lot Application **DP**

Load: Static, 20,000 lbs

Stainless steel hex head bolts are standard on bolt down covers. Boltless covers are also available. Consult factory.

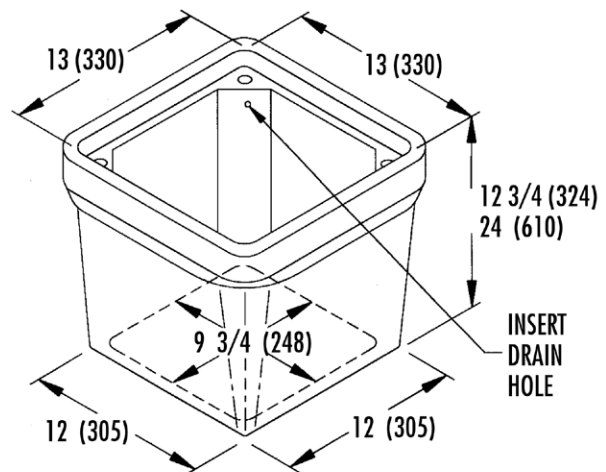
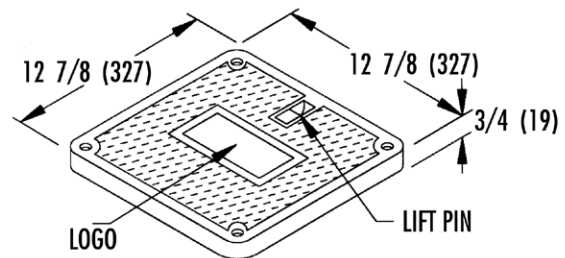

Dimensions: Inches (mm)
Weight: lbs (kg)

Part No.	Description	Material	Weight
PCB121212A04	Box, 12", w/ no floor	PC	29 (13)
PCB121212A14	Box, 12", w/ floor	PC	33 (15)
PCB121212AN4	Box, 12", w/ floor & gasket	PC	33 (15)
PCB121212A24	Box, 12", w/ mouseholes	PC	28 (13)
PCB121224A04	Box, 24", w/ no floor	PC	52 (24)
PCB121224A14	Box, 24", w/ floor	PC	56 (25)
PCB121224AN4	Box, 24", w/ floor & gasket	PC	56 (25)
PCB121224A24	Box, 24", w/ mouseholes	PC	51 (23)
PCC121200A04	Cover, 2 bolt - 20K	PC	9 (4)
PCC121200B04	Cover, 4 bolt - 20K	PC	9 (4)